

IMPORTANT SAFETY RULES

Please read, understand, and follow all instructions carefully before installing and using this product. Keep for future reference.

C330

Krystal Clear™ Filter Pump
Certified Model Number 602
220 - 240 V~, 50 Hz, 30 W
Hmax 1.0 m, Hmin 0.19 m, IPX5/IPX7
Max. Water Temperature 35 °C



For illustrative purposes only.

Don't forget to try these other fine Intex products: pools, pool accessories, inflatable pools and in-home toys, airbeds and boats available at fine retailers or visit our website.

Due to a policy of continuous product improvement, Intex reserves the right to change specifications and appearance, which may result in updates to the instruction manual without notice.

OWNER'S MANUAL

INTEX®

©2022 Intex Marketing Ltd. - Intex Development Co. Ltd. - Intex Recreation Corp.
All rights reserved/Tous droits réservés/Todos los derechos reservados/Alle
Rechte vorbehalten. Printed in China/Imprimé en Chine/Impreso en China/
Gedruckt in China.

®™ Trademarks used in some countries of the world under license from/®™ Marques utilisées dans certains pays
sous licence de/Marcas registradas utilizadas en algunos países del mundo bajo licencia de/Warenzeichen verwendet
in einigen Ländern der Welt in Lizenz von/Intex Marketing Ltd. to/à/a/an Intex Development Co. Ltd., Hong Kong &
Intex Recreation Corp., P.O. Box 1440, Long Beach, CA 90801 • Distributed in the European Union by/Distribué dans
l'Union Européenne par/Distribuido en la unión Europea por/Vertrieb in der Europäischen Union durch/Intex Trading B.V.,
Ettenseweg 46, 4706 PB Roosendaal – The Netherlands • Distributed in the UK by Unitex Service (UK) Limited, 21
Holborn Viaduct, London EC1A 2DY, UK.
www.intexcorp.com

257-*A*-R0-2304

TABLE OF CONTENTS

Warnings.....	3
Parts Reference.....	4
Setup Instructions.....	5-7
Maintenance.....	7-8
Pool Care and Chemicals.....	8
Long Term Storage.....	8
Troubleshooting Guide.....	9
Common Pool Problems.....	10
General Aquatic Safety.....	10
Limited Warranty.....	11

IMPORTANT SAFETY RULES

Read, Understand and Follow All Instructions Carefully Before Installing and Using this Product.

READ AND FOLLOW ALL INSTRUCTIONS

WARNING

- Always supervise children and those with disabilities.
- Children must stay away from this product and electrical cord(s).
- Children shall not play with the appliance. Cleaning and user maintenance shall not be made by children without supervision.
- This appliance can be used by children aged from 8 years and above and persons with reduced physical, sensory or mental capabilities or lack of experience and knowledge if they have been given supervision or instruction concerning use of the appliance in a safe way and understand the hazards involved.
- Assembly and disassembly by adults only.
- Risk of electric shock. Connect this product only to a grounding type receptacle protected by a ground-fault circuit interrupter (GFCI) or residual current device (RCD). Contact a qualified electrician if you cannot verify that the receptacle is protected by a GFCI/RCD. Use a qualified electrician to install the GFCI/RCD, which has a maximum rate of 30mA. Do not use a portable residual current device (PRCD).
- Always unplug this product from the electrical outlet before removing, cleaning, servicing or making any adjustment to the product.
- The plug must be accessible after product is installed.
- Do not bury the electrical cord. Locate the cord where it will not be damaged by lawn mowers, hedge trimmers and other equipment.
- The supply cord cannot be replaced. If the cord is damaged the appliance should be scrapped.
- To reduce the risk of electric shock, do not use extension cords, timers, plug adaptors or converter plugs to connect unit to electric supply; provide a properly located outlet.
- Do not attempt to plug in or unplug this product while standing in water or when your hands are wet.
- Keep the plug of this product more than 3.5m away from the pool.
- Position this product away from the pool, so as to prevent children from climbing on it and accessing the pool.
- Do not operate this product when the pool is occupied.
- This product is for use with storable pools only. Do not use with permanently installed pools. A storable pool is constructed so that it may be readily disassembled for storage and reassembled to its original configuration.
- The appliance is intended only for household use.
- This product is intended to be used only for the purposes described in the manual!

FAILURE TO FOLLOW THESE WARNINGS MAY RESULT IN PROPERTY DAMAGE, ELECTRIC SHOCK, ENTANGLEMENT OR OTHER SERIOUS INJURY OR DEATH.

These product warnings, instructions and safety rules provided with the product represent some common risks of water recreation devices and do not cover all instances of risk and danger. Please use common sense and good judgement when enjoying any water activity.

PARTS REFERENCE

Before assembling your product, please take a few minutes to check the contents and become familiar with all the parts.

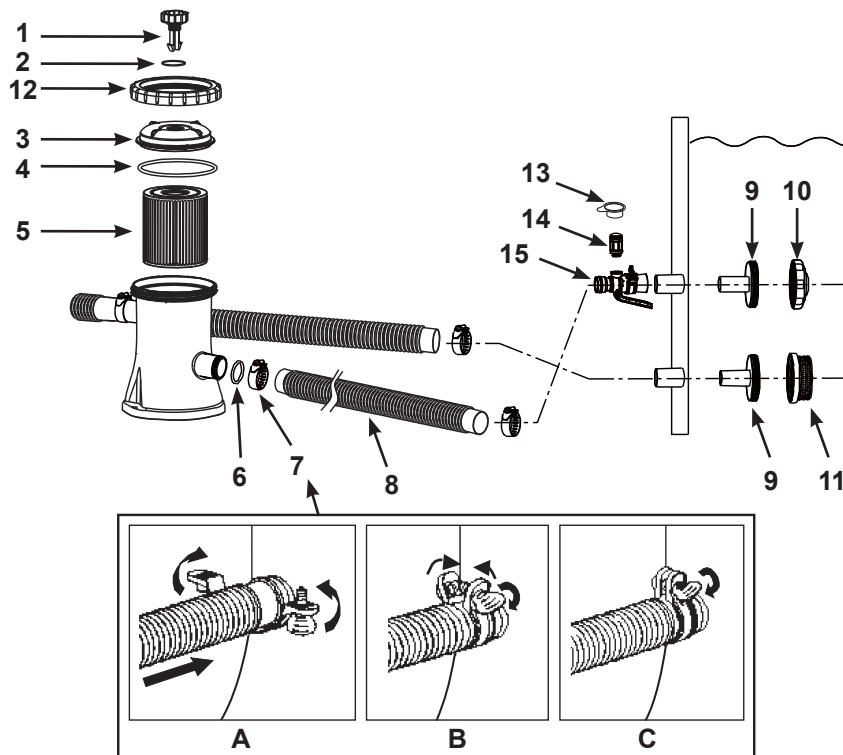

NOTE: Drawings for illustration purpose only. May not reflect actual product. Not to scale.

REF. NO.	DESCRIPTION	QTY.	SPARE PART NO.
1	AIR RELEASE VALVE	1	10460
2	VALVE O-RING	1	10264
3	FILTER HOUSING COVER	1	11917
4	COVER SEAL	1	11919
5	FILTER CARTRIDGE	1	29007
6	HOSE SEAL	2	10134
7	HOSE CLAMP	4	11489
8	HOSE	2	10399
9	STRAINER CONNECTOR	2	11070
10	POOL INLET JET NOZZLE	1	13162
11	STRAINER GRID	1	12197
12	THREADED FILTER HOUSING COLLAR	1	11918
13	AIR JET VALVE CAP	1	12373
14	AIR JET VALVE	1	12363
15	POOL INLET AIR ADAPTOR	1	12366

Type of filter medium	Synthetic cartridge #29007
-----------------------	----------------------------

When ordering parts, be sure to quote the model number and part numbers. No tools are required for the assembly.

SETUP INSTRUCTIONS

Be sure you have access to water to fill the pool and chemicals for the water.

IMPORTANT: This filter pump is shipped with the air release valve (1) open (open the air release valve if necessary). DO NOT replace the air release valve until you reach STEP #8. Failure to follow these instructions will result in air trapped inside filter housing; the motor will run dry, be noisy and malfunction.

1. Assemble above-ground-pool first. Carefully follow the pool's installation instructions.
2. Place the filter pump the length of the hose away from the pool wall where the lower black protruding hose connection is "sticking-out". Ensure the filter pump is accessible at all time for service and maintenance.
3. Insert the nozzle union (9 & 10) into the upper protruding hose connections, and then attach the pool inlet air adaptor (15) to the upper protruding fitting. Screw the air jet valve (14) over the pool inlet air adaptor (15). Then insert the strainer union (9 & 11) into the lower protruding hose connections. The hoses (8) fit over the strainers inserted into the connections.
4. There are two hoses to be connected to the filter pump hose connections. With hose clamps (7), fasten one of the hoses (8) to the lower protruding hose connection (marked "+" on the pool liner) and to the upper pump connection (marked "+").
5. Connect the second hose to the pool inlet air adaptor (15) and to the lower pump connection. Make sure all the hose clamps (7) are tight. **NOTE:** Make sure the air jet valve (14) is securely tighten onto the pool inlet air adaptor (15) and facing up.
6. In a counter-clockwise motion unscrew the threaded filter housing collar (12) from the filter housing. Grasp and remove the housing cover (3). Check to see if a cartridge is inside the housing. If yes, replace the cover, finger tighten the housing collar (12) back onto the filter housing.
7. Fill the pool to a level of at least 1-2 inches above the top connection. The water will automatically flow down into the pump.
8. When water starts flowing out of the air release valve hole, screw in the air release valve back into the filter housing cover. Do not over tighten the valve. **NOTE: Venting the system is necessary for air to escape as the filter housing fills with water.**
9. Connect the filter pump to the power outlet. The filter pump is now filtering the water.

WARNING

Risk of electric shock. Connect this product only to a grounding type receptacle protected by a ground-fault circuit interrupter (GFCI) or residual current device (RCD). Contact a qualified electrician if you cannot verify that the receptacle is protected by a GFCI/RCD. Use a qualified electrician to install the GFCI/RCD, which has a maximum rate of 30mA. Do not use a portable residual current device (PRCD).

10. Operate the filter pump until the desired water clarity is obtained.
NOTE: Never put pool chemicals directly into the filter pump. This may damage the pump and void the warranty.

SETUP INSTRUCTIONS (continued)

⚠ WARNING

Position this product away from the pool, so as to prevent children from climbing on it and accessing the pool.

It is essential to change any damaged element or set of elements as soon as possible. Use only parts approved by the manufacturer.

To inspect and change the filter cartridge, disconnect line cord, unscrew the pool inlet nozzle (10) and strainer grid (11) from the strainer connectors and insert the hat-like plugs into the strainer connectors before servicing the filter. After service, open the air release valve, remove the plugs, allow any air to escape through the valve before tightening the valve again and replace the pool inlet nozzle (10) and strain grid (11). The pump is now primed with water again and may be turned on.

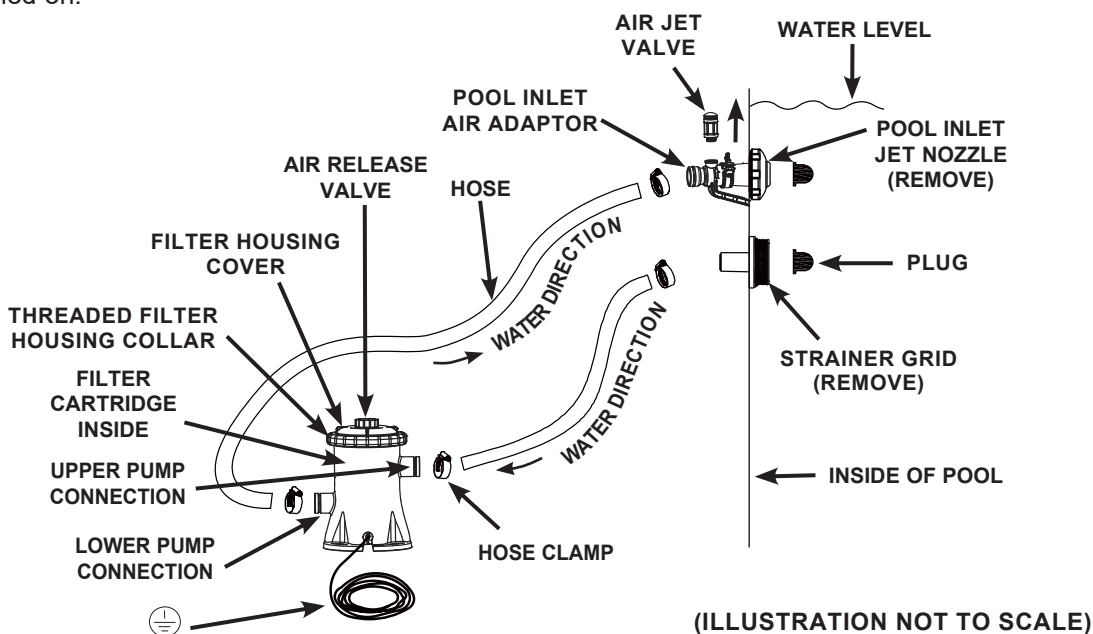

The power cord plug to the 220-240 volt electrical power source of the filter pump must be positioned more than 3.5 m away from the pool walls. Check your local authorities to determine the appropriate standard and requirements for "electrical installation of swimming pools and basins equipment". The following table is for reference only:

Country/Region	Standard Number
International	IEC 60364-7-702
France	NF C 15-100-7-702
Germany	DIN VDE 0100-702
The Netherlands	NEN 1010-702

FILTER PUMP STATIONARY MOUNTING OPTION

There are three mounting holes located at the bottom of the filter pump base. These holes are provided because various country's regulations, especially in the European community, require the filter pump to be secured to the ground or to a base in a permanent upright position. These three holes form a triangle pattern and the holes are slotted with a 7mm width. The filter pump can be mounted on a cement base or onto a wooden structure to prevent accidental falling over. Total assembly must exceed 18kg. The drawings on the following show two possible ways of upright mounting.

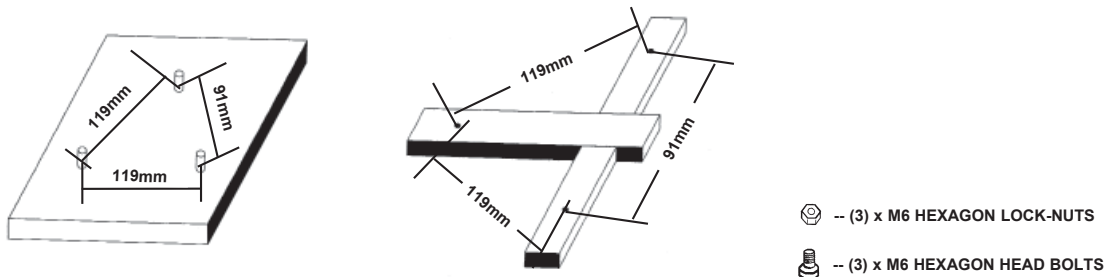

CLEANING OR REPLACING FILTER CARTRIDGE

It is recommended that the filter cartridge be replaced at least every 2 weeks. Regularly monitor the filter clogging level.

1. Make sure filter pump is not operating. Disconnect line cord.
2. To prevent water from escaping the pool, unscrew the pool inlet nozzle (10) and strainer grid (11) from the strainer connectors and insert the hat-like plugs into the strainer connectors.
3. In a counter-clockwise motion, remove the filter housing collar (12) and threaded cover (3). Be careful not to lose the cover seal (4).
4. Remove filter cartridge (5) to clean it. The filter may be cleaned from the spray from a water hose.
5. Use judgement as to whether cartridge needs to be replaced. Only use the original Intex cartridge for replacement. See "Parts Reference" section for detail.
6. Return cartridge to filtering position.
7. Return the seal (4) and threaded cover (3) to their original positions and in a clockwise direction rescrew the housing collar (12) onto the filter housing.
8. After service, open the air release valve, remove the plugs, allow any air to escape through the valve before tightening the valve again and replace the pool inlet nozzle (10) and strainer grid (11). The pump is now primed with water again and may be turned on.
9. Check the inlet and outlet openings regularly to ensure they are not obstructed thus preventing a good filtration.
10. The disposal of any used filter media should be in accordance with applicable local regulation and legislation.

POOL CARE AND CHEMICALS

- All pools require care to keep the water clear and hygienically clean. With proper chemical control, your filter will help attain this objective. Consult your pool supply dealer for instructions regarding the proper use of chlorine, algaecide and other chemical agents required for sparkling clear water.
- Keep pool chemicals away from children.
- Do not replenish chemicals in pool while pool is occupied. Skin or eye irritations could occur.
- Daily pH checking and chemical treatment of the water is very important and can not be overemphasized. Chlorine, algaecide and maintenance of proper pH levels are required when filling the pool as well as during the season. Consult your local swimming pool supply store for instructions.
- The season's first filling of the pool may have brackish water requiring extra water additives and extra filter changes. Do not allow swimming in pool until the pH level is balanced. Consult your local swimming pool supply store for instructions.
- Keep spare filter cartridges on hand. Replace cartridges every two weeks.
- Chlorinated water may damage lawns, gardens or shrubbery as children play in the pool and splash water outside the pool. Lawn areas underneath the pool liner will be destroyed. Note that some types of grass may grow through the liner.
- Filter run time depends on pool size, weather and usage level. Experiment with various run times so as to produce clean clear water.
- European standard EN16713-3 lists some additional pool water quality and water treatment information that can be found at www.intexcorp.com/support.

CAUTION

Concentrated chlorine solutions may damage the pool liner. Always follow the chemical manufacturer's directions, and the health and hazard warnings.

LONG TERM STORAGE & WINTERIZATION

1. Before emptying your pool for long term storage, or relocation, be sure the water is directed towards an acceptable drain water receptacle away from the house. Check local regulations for specific directions regarding disposal of swimming pool water.
2. Now, drain the pool.
3. When the pool is empty, disconnect all pool hoses **(8)** from the pool and filter pump, simply reverse the set up instructions.
4. Remove the filter cartridge as shown in the Filter Cartridge Cleaning section, steps 2 thru 4.
5. Remove the nozzle and strainer unions from the pool wall. Place the wall plugs into the hose connections. Loosen clamps **(7)** securing the strainer connectors **(9)** before removal.
6. Drain water from the filter pump housing.
7. Leave filter pump pieces and hoses outside to thoroughly air dry.
8. Depending on the cartridge **(5)** usage, a new cartridge may be needed for next season, keep a spare available.
9. Cover the seal **(4)**, air release valve O-ring **(2)** and hose seals **(6)** with petroleum jelly to preserve its resilience during storage.
10. Store the unit and accessories in a dry place. The storage's temperature should be controlled, between 32 degrees Fahrenheit (0 degrees Celsius) and 104 degrees Fahrenheit (40 degrees Celsius) storage location.
11. The original packing can be used for storage.

TROUBLESHOOTING GUIDE

TROUBLE	CAUSE	SOLUTION
FILTER MOTOR FAILS TO START	<ul style="list-style-type: none"> The motor is not plugged in. The GFCI/RCD circuit breaker is tripped. Motor too hot and overload protection is shut off. 	<ul style="list-style-type: none"> Filter cord must be plugged into a 3 wire outlet that is protected by a Class A Ground Fault Circuit Interrupter, or RCD. Reset circuit breaker. If circuit breaker trips repeatedly, your electrical system may have a defect. Turn off circuit breaker and call an electrician to correct the problem. Let the motor cool down.
FILTER DOESN'T CLEAN POOL	<ul style="list-style-type: none"> Improper chlorine or pH levels. Filter cartridge is dirty. Damaged cartridge. Excessively dirty pool. The strainer screen is restricting the water flow. 	<ul style="list-style-type: none"> Adjust the chlorine and pH level. Consult your local swimming pool supply stores. Clean or replace cartridge. Check the cartridge for holes. Replace if damaged. Operate the filter for longer periods. Clean the strainer screen at the inlet.
FILTER DOESN'T PUMP WATER OR FLOW IS VERY SLOW	<ul style="list-style-type: none"> Clogged inlet or discharge. An air leak on the intake line. Scale or buildup on cartridge. Excessively dirty pool. Dirty filter cartridge. The nozzle and strainer connection are reversed. Pool inlet air adaptor connected to the wrong fitting. 	<ul style="list-style-type: none"> Clear any obstructions in the intake hose by discharging it inside pool wall. Tighten hose clamps, check hoses for damage, check pool water level. Replace cartridge. Clean cartridge more often. Install the nozzle at the upper position of the pool inlet, and the strainer at the lower position of the pool outlet. Make sure the pool inlet air adaptor is connected to the pool inlet upper fitting.
PUMP DOESN'T WORK	<ul style="list-style-type: none"> Low water level. Strainer screen plugged up. An air leak on the intake hose. Faulty motor or the impeller is jammed. An air lock inside the cartridge chamber. 	<ul style="list-style-type: none"> Fill pool to correct water level. Clean strainer screens at pool inlet. Tighten hose clamps, check hose for damage. Clear any sticks or leaves in the intake hose. Open the release valve at top of pump.
TOP COVER LEAKING	<ul style="list-style-type: none"> O-ring missing. Cover or air release valve are not tight. 	<ul style="list-style-type: none"> Remove cover & check for O-ring. Tighten cover or valve (Manually).
HOSE LEAKING	<ul style="list-style-type: none"> Hose clamps are not well-fitted. Hose o-ring dislodged when connecting the hose. Hose broken. 	<ul style="list-style-type: none"> Tighten or change hose clamps. Put the o-ring back into the groove. Replace a new hose.
AIR LOCK	<ul style="list-style-type: none"> There's air trapped in the pump housing and inlet hose. 	<ul style="list-style-type: none"> Open air release valve, lift and lower the inlet hose until water starts to flow out of the air release valve, close air release valve.
POOL INLET AIR ADAPTOR/AIR JET VALVE LEAKING	<ul style="list-style-type: none"> Hose clamps are not well-fitted. Air jet valve is not tight and facing up. Air jet valve internal seal blocked. Air jet valve internal seal dirty. Air jet valve broken. 	<ul style="list-style-type: none"> Tighten or reinstall hose clamps. Tighten air jet valve and make sure it's facing up. Plug in the pump and run for few seconds, then unplug, repeat 3 times. Remove air jet valve, flush dirt out with water and replace valve back. Replace a new air jet valve.
SMALL LEAK FROM AIR JET VALVE WHEN PUMP IS ON	<ul style="list-style-type: none"> Accessories attached to the water circulation line. 	<ul style="list-style-type: none"> Remove all the accessories (such as solar mat, auto pool cleaner, LED light) from the water circulation line and place the air jet valve cap (13) over the air jet valve (14). Do not cover the air jet valve (14) with the valve cap (13) under normal situation or when the pump is operating.

COMMON POOL PROBLEMS

PROBLEM	DESCRIPTION	CAUSE	SOLUTION
ALGAE	<ul style="list-style-type: none"> Greenish water. Green or black spots on pool liner. Pool liner is slippery and/or has a bad odor. 	<ul style="list-style-type: none"> Chlorine and pH levels need adjustment. 	<ul style="list-style-type: none"> Super chlorinate with shock treatment. Correct pH to your pool store's recommended level. Vacuum pool bottom. Maintain proper chlorine level.
COLORED WATER	<ul style="list-style-type: none"> Water turns blue, brown, or black when first treated with chlorine. 	<ul style="list-style-type: none"> Copper, iron or manganese in water being oxidized by the added chlorine. This is Common. 	<ul style="list-style-type: none"> Adjust pH level to the recommended level. Run filter until water is clear. Clean cartridge frequently.
SUSPENDED MATTER IN WATER	<ul style="list-style-type: none"> Water is cloudy or milky. 	<ul style="list-style-type: none"> "Hard water" caused by a too high pH level. Chlorine content is low. Foreign matter in water. 	<ul style="list-style-type: none"> Correct the pH level. Check with your pool dealer for advice. Adjust the chlorine level. Clean or replace your filter.
CHRONIC LOW WATER LEVEL	<ul style="list-style-type: none"> Level is lower than on previous day. 	<ul style="list-style-type: none"> Rip or hole in pool liner or hoses. The drain valves are loose. 	<ul style="list-style-type: none"> Repair with a patch kit. Finger tighten all caps.
SEDIMENT ON POOL BOTTOM	<ul style="list-style-type: none"> Dirt or sand on pool floor. 	<ul style="list-style-type: none"> Heavy use, getting in and out of pool. 	<ul style="list-style-type: none"> Use Intex pool vacuum to clean bottom of pool.
SURFACE DEBRIS	<ul style="list-style-type: none"> Leaves, insects etc. 	<ul style="list-style-type: none"> Pool too close to trees. 	<ul style="list-style-type: none"> Use Intex pool skimmer.

IMPORTANT

If you continue to experience difficulty, please contact our Consumer Service Department for assistance. See separate "Authorized Service Centers" sheet.

GENERAL AQUATIC SAFETY

Water recreation is both fun and therapeutic. However, it involves inherent risks of injury and death. To reduce your risk of injury, read and follow all product, package and package insert warnings and instructions. Remember, however, that product warnings, instructions and safety guidelines cover some common risks of water recreation, but do not cover all risks and or dangers.

For additional safeguards, also familiarize yourself with the following general guidelines as well as guidelines provided by nationally recognized Safety Organizations:

- Demand constant supervision. A competent adult should be appointed as a "lifeguard" or water watcher, especially when children are in and around the pool.
- Learn to swim.
- Take the time to learn CPR and first aid.
- Instruct anyone who is supervising pool users about potential pool hazards and about the use of protective devices such as locked doors, barriers, etc.
- Instruct all pool users, including children what to do in case of an emergency.
- Always use common sense and good judgement when enjoying any water activity.
- Supervise, supervise, supervise.

LIMITED WARRANTY

Your Krystal Clear™ Filter Pump has been manufactured using the highest quality materials and workmanship. All Intex products have been inspected and found free of defects prior to leaving the factory. This limited warranty applies only to the Krystal Clear™ Filter Pump and accessories listed below.

This limited warranty is in addition to, and not a substitute for, your legal rights and remedies. To the extent that this warranty is inconsistent with any of your legal rights, they take priority. For example, consumer laws across the European Union provide statutory warranty rights in addition to the coverage you receive from this limited warranty: for information on EU-wide consumer laws, please visit the European Consumer Center website at http://ec.europa.eu/consumers/ecc/contact_en/htm.

The provisions of this limited warranty apply only to the original purchaser and are not transferable. This limited warranty is valid for the period noted below from the date of the initial retail purchase. Keep your original sales receipt with this document, as proof of purchase will be required and must accompany warranty claims or the limited warranty will be invalid.

Krystal Clear™ Filter Pump Warranty – 2 Years
Hoses & Fittings Warranty – 180 days

If you find a manufacturing defect in the Krystal Clear™ Filter Pump during the warranty periods noted above, please contact the appropriate Intex Service Center listed in the separate "Authorized Service Centers" sheet. If the item is returned as directed by the Intex Service Center, the Service Center will inspect the item and determine the validity of the claim. If the item is covered by the provisions of the warranty, the item will be repaired or replaced, with the same or comparable item (at Intex's choice) at no charge to you.

Other than this warranty, and other legal rights in your country, no further warranties are implied. To the extent possibly in your country, in no event shall Intex be liable to you or any third party for direct or consequential damages arising out of the use of your Krystal Clear™ Filter Pump, or Intex or its agents' and employees' actions (including the manufacture of the product). If your country does not allow the exclusion or limitation of incidental or consequential damages, this limitation or exclusion does not apply to you.

You should note that this limited warranty does not apply in the following circumstances:

- If the Krystal Clear™ Filter Pump is subject to negligence, abnormal use or application, accident, improper operation, improper voltage or current contrary to operating instructions, improper maintenance or storage;
- If the Krystal Clear™ Filter Pump is subject to damage by circumstances beyond Intex's control, including but not limited to, ordinary wear and tear and damage caused by exposure to fire, flood, freezing, rain, or other external environmental forces;
- To parts and components not sold by Intex; and/or
- To unauthorized alterations, repairs or disassembly to the Krystal Clear™ Filter Pump by anyone other than Intex Service Center personnel.

The costs associated with the loss of pool water, chemicals or water damage are not covered by this warranty. Injury or damage to any property or person is not covered by this warranty.

Read the owner's manual carefully and follow all instructions regarding proper operation and maintenance of your Krystal Clear™ Filter Pump. Always inspect your product prior to use. This limited warranty will be void if use instructions are not followed.